

NX P&ID Designer

Starting with a logical representation of a piping system can simplify the design process

Benefits

- Accelerates creation of P&ID diagrams
- Fast definition of piping, flow, connectivity and equipment
- Improved P&ID quality
- Promotes design re-use with shared and managed libraries
- Streamlines pipe run creation and equipment reconfiguration
- Better design accuracy through associativity of 2D diagrams and 3D mechanical routing
- Fewer errors with automated validation checking
- Easier change implementation
- Improved lifecycle management through release, revision and obsolescence
- Reduced project completion time
- Fast searching of equipment, runs, sheets, systems

Summary

A common way to simplify design for projects such as ships or plants is to start with block diagrams, also called process, flow or logical diagrams. This gives the designer the ability to define sizes and equipment types, and to prove system operation before committing any time to 3D design. In many cases customers want to review and approve a system before design work is started. The ultimate diagramming tool would allow a fast way to capture flow and connectivity to drive 3D pipe routing, all while being managed. The goals are to accelerate design and re-use data to help reduce project completion times.

Siemens Digital Industries Software NX™ P&ID Designer software is a 2D piping and instrumentation diagramming tool that helps engineers create functional or logical designs of piping and instrumentation systems. The application is used by piping and instrumentation diagram (P&ID) designers in any industry where liquid or gas needs to be transported through pipes. The software includes easy-to-use authoring capabilities, libraries that integrate 2D and 3D, connectivity validation at

design time, 2D-to-3D integration, and equipment-level data management.

A faster way to author diagrams

With NX P&ID Designer you can quickly and easily create P&ID diagrams. Commands are laid out in a methodical manner on the ribbon toolbar and navigators for tracking runs and systems help users visualize how diagrams are organized. P&ID Designer helps customers focus on design and spend less time on diagram creation.

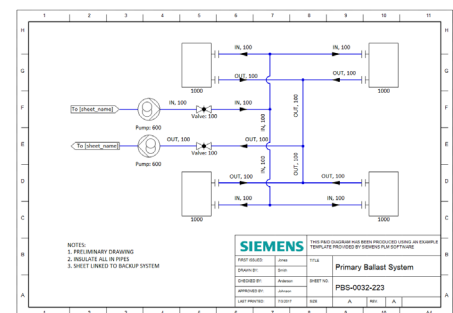

Fast equipment placement

When designing a system, users of P&ID Designer choose equipment from a shared library and with a simple click-to-place operation, with control over orientation. An auto-repeat function accelerates repetitive placements. Equipment can be placed onto a pipe and sized automatically to match the pipe stock. Pipe specifications can be used to make certain that placed equipment is compatible with its operating conditions. Design calculations can be stored with placed equipment for keeping a permanent record of calculations.

NX P&ID Designer

Features

- Comprehensive P&ID authoring functions
- Intuitive user interface
- Shared and managed libraries of pipes, equipment, connectors
- Simple equipment placement
- Automated tagging
- Equipment-level data management
- Dynamically associated 2D and 3D design information
- Cross-probing between 2D diagrams and 3D models
- Comprehensive lifecycle data management
- Real-time validation checking

Automatic annotations

During the authoring process with P&ID Designer, much of the annotation work is automated. As designers place symbols and draw pipes, equipment tags and line numbering are added automatically in formats configured by the designer. Equipment tags are automatically added when symbols are placed, and line numbering is applied to pipes as they are drawn, each with a configurable format. When the designer draws pipe lines to tanks, the appropriate nozzles are added automatically, and when connecting pipes to other pipes, tees are inserted automatically. The software also automates drawing of pipe jumpers and determines the minimum number of bends required to maintain single straight-line connections.

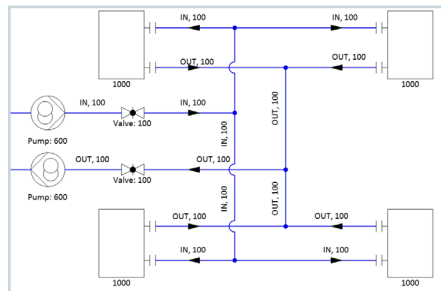

Pipe runs

Pipe runs are used to organize pipes and in-line equipment in a sequential order and aid in transporting diagram data to the 3D mechanical pipe routing process. Runs are automatically managed during creation, and reconfiguration of equipment in runs is a simple drag-and-drop operation. Users can create diagrams without runs or sized equipment, enabling faster exploration during the conceptual design phase. Runs across sheets can be connected using off-sheet connectors.

Database-driven libraries

Libraries are the heart of any diagramming system, and designers need a wide variety of equipment including pumps, valves, pipe stocks, and sheet templates. Users also want to be sure they are using approved equipment, so

database storage is generally a mandatory requirement. P&ID Designer offers a sample library of equipment, and users can extend the library by adding equipment as needed. All library items are managed in Teamcenter® software so that a common set of data is shared among users, who have full lifecycle control over release, revisions or even obsolescence. With managed libraries, users always have confidence that placed equipment is approved and up-to-date.

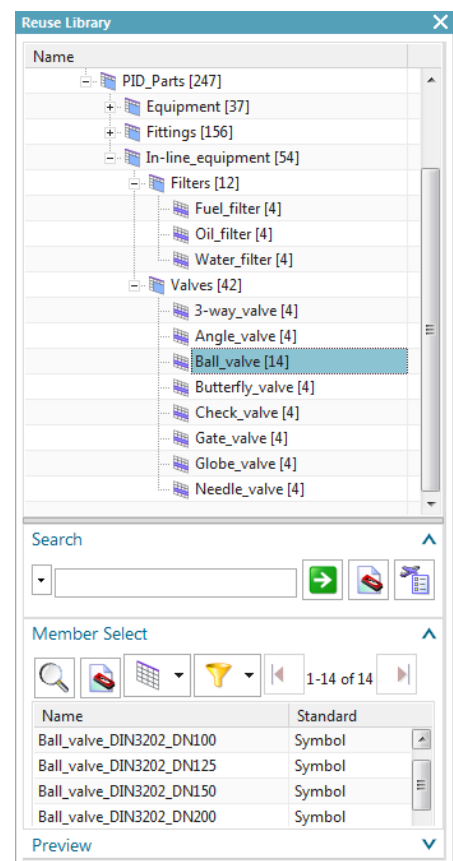

Diagramming to routing

Equipment used in diagrams can have associated 3D counterparts so that attributes and connection ports are matched. This association ensures that pipe connections created in 3D will exactly match the equipment and connection definition from the 2D diagram.

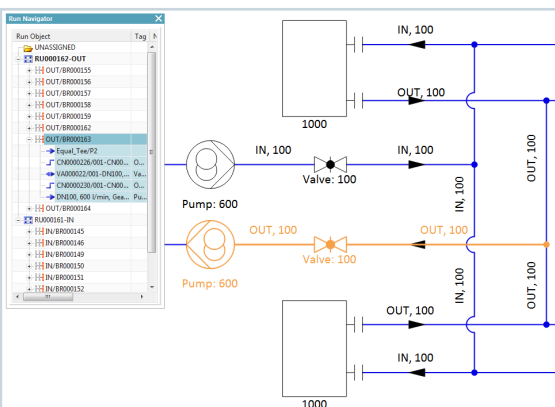

Common pipe specifications

Pipe specifications are also managed using Teamcenter and shared between 2D diagramming and 3D mechanical routing. Users can specify attributes for a pipe run during diagram development, and the re-use library will automatically filter out incompatible equipment. Also, unnecessary items such as fittings and gaskets will be automatically omitted during diagram creation, but placed during 3D routing.

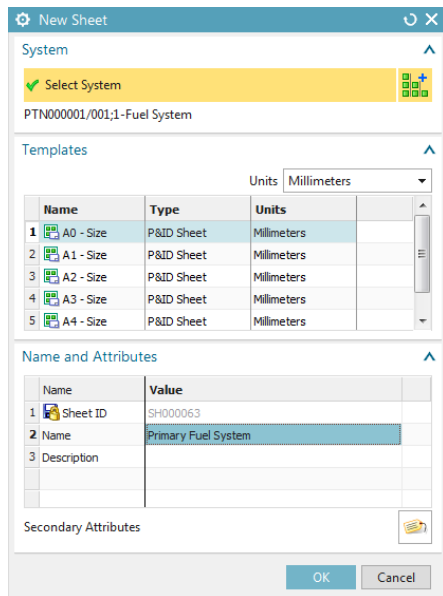

Custom sheet templates

Piping systems are drawn on sheets and users can create any number of template sheets to match company, customer or industry standards. Sheet templates can include borders, zones, and title blocks that prompt the user for data on usage. If a design grows past the sheet size, the sheet can be resized.

Symbol authoring

P&ID Designer also comes with library authoring tools that enable users to create library elements for use in diagramming and 3D mechanical routing. Users can create virtually any type of equipment, specify the attributes, associate the 3D component, and assign connection ports. Users can also author pipe stocks and line types.

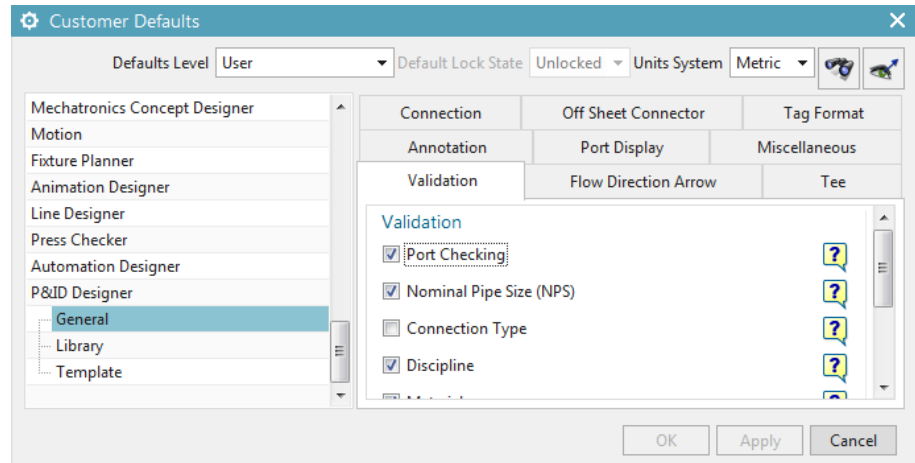

Connectivity validation

P&ID designers need to verify that pipes and their connected equipment are compatible before sending the diagram to the routing team. While pipe specifications ensure compatibility within a design standard, P&ID Designer makes additional checks to validate that pipe diameters, connection disciplines, and connection types are consistent between equipment. Customers can create more accurate diagrams the first time, thereby reducing costly rework or manufacturing errors.

Feedback at design time

During diagram design, users can rely on instant feedback if an incompatible connection is being made. P&ID Designer includes automated checks that warn the user if a mismatch is found between nominal pipe size, connection type, discipline, and material. An optional check is available to guide selection of the correct in-line component when equipment is placed onto a pipe. Another option checks the port size on equipment and automatically selects the appropriate pipe stock.

Diagramming-to-routing integration

The goal for most companies is to re-use P&ID data directly in the 3D routing process. Re-using both equipment and the connection map from 2D saves routing time and eliminates rework. P&ID Designer has a streamlined approach for moving diagram data to 3D routing, so that runs opened in 3D include all equipment and from-to information. The diagram can be displayed during routing to help users

visualize how the 3D route maps back to the diagram. P&ID Designer helps customers minimize design duplication by leveraging data created in 2D for the 3D design process.

Selective routing

Runs defined in a P&ID diagram can be used to drive the 3D mechanical routing process. The process is very flexible. Designers can pick and choose any run from any system to route to get a jump start on the routing process.

Cross-probing

To assist the 3D routing process, the associated 2D diagram can be displayed, enabling the user to view equipment highlighted in both 2D and 3D during the selection process. This cross-probing capability helps verify that components are placed in the correct sequence. The routing run navigator also shows which diagramming items have been placed in 3D, ensuring routing completeness before the approval process.

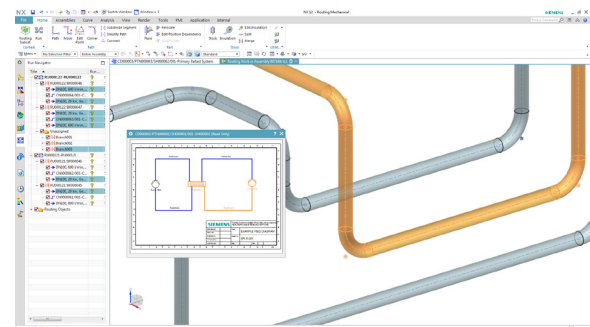

Smart updates

When changes are made to the diagram, the run navigator in 3D routing alerts the designer of the changes when the design is opened. The cross-probing window displays the updated diagram that helps the user to easily implement the change. Throughout the 3D design process, an indicator in the navigator shows what is complete and what remains to be done.

Object-level data management using Teamcenter

Companies require P&ID systems to be database-oriented, meaning libraries and diagrams are stored in a database for all users to access. Ideally, users have control over equipment using revisions to manage access. NX P&ID Designer is built on Teamcenter, which stores and manages all aspects of a diagram. Equipment libraries, pipe specifications, sheet templates, systems, sheets, runs, the equipment on a sheet, and even the connectivity model are managed in Teamcenter. This single source of accurate, approved and up-to-date information gives customers the ability to control every aspect of a diagram and supports re-use.

Searching from systems to equipment

Since all P&ID items are managed in Teamcenter, users can quickly find systems, runs, sheets and even equipment used on a sheet. Full or partial IDs can initiate the search and if found, the user can open its sheet directly.

Lifecycle control from systems to equipment

With P&ID Designer, users can manage the entire lifecycles of systems, sheets, runs and equipment. These items can be released, revised, and at the end of life, obsoleted. This gives the ability to ensure only the latest and approved equipment is used in a design. If the user attempts to modify a released item, P&ID Designer automatically creates an item revision and prompts the user with details of the process.

More productivity for complex piping projects

For complex projects where piping is involved, P&ID Designer can simplify design, saving time and money. The diagramming software helps designers create piping and instrumentation diagrams faster and easier, ensures compatible connections, provides a streamlined path to 3D routing, and offers complete data management. For mechanical routing users, an integration module is available that provides the ability to read diagram data into 3D. With either application, companies can streamline the design of complex projects.

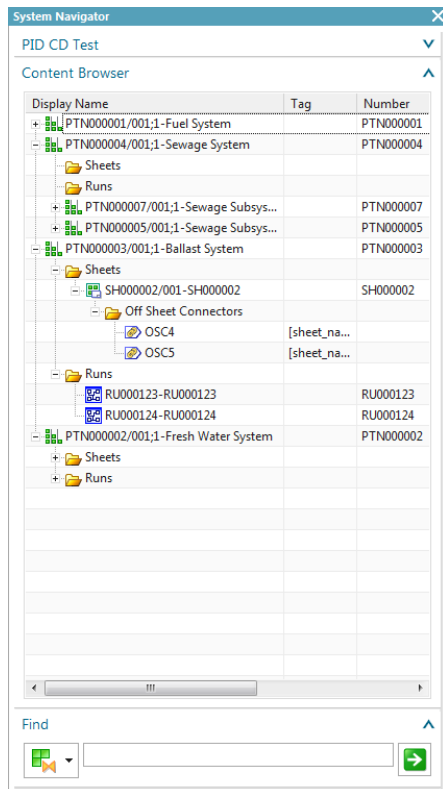

Siemens Digital Industries Software
[siemens.com/plm](https://www.siemens.com/plm)

Americas +1 314 264 8499
 Europe +44 (0) 1276 413200
 Asia-Pacific +852 2230 3333

Restricted © Siemens 2019. Siemens, the Siemens logo and SIMATIC IT are registered trademarks of Siemens AG. Camstar, D-Cubed, Femap, Fibersim, Geolus, GO PLM, I-deas, JT, NX, Parasolid, Polarion, Simcenter, Solid Edge, Syncrofit, Teamcenter and Tecnomatix are trademarks or registered trademarks of Siemens Product Lifecycle Management Software Inc. or its subsidiaries or affiliates in the United States and in other countries. All other trademarks, registered trademarks or service marks belong to their respective holders.
 64195-C5 5/19 Y