



DIGITAL INDUSTRIES SOFTWARE

NX X Design solutions

Delivering prepackaged high-performance CAD solutions

Benefits

- Boosts product design efficiency
- Accelerates mechanical design processes
- Improves collaboration
- Reduces design process waste
- Improves design quality
- Uses a single environment to facilitate processes from model to printed part

Features

- End-to-end mechanical product design solutions with a rich set of supporting tools
- High-performance modeling, drafting and comprehensive assembly design powered by synchronous technology and Convergent Modeling

Summary

NX™ X software products are prepackaged Software as a Service (SaaS) solutions delivering the high-performance computer-aided design (CAD) capabilities of NX software with all the associated flexibility, security and scalability benefits of SaaS. Based on the same NX architecture and leveraging the same data model, Siemens provides one NX—with one common user experience—with different deployment options available to meet your business needs. They offer competitively priced solutions tailored to specific product development roles, practices and processes in three performance tiers. Value-added upgrades are available to move customers from one tier to the next. Each package delivers complete capabilities for production work.

The NX X Design solutions are delivered via cloud SaaS named-user licensing. Token licensing exclusively extends and enhances these solutions. Traditional on-premises software is also available through NX Design solutions.

NX X Design Standard, Advanced and Premium solutions include base-level data management and everything you need to integrate with Teamcenter® software to provide optional extended engineering process management tools through scalable collaboration and advanced management. NX and Teamcenter are part of the Siemens Xcelerator business platform of software, hardware and services.

Features continued

- Comprehensive, preconfigured SaaS solutions tailored for the full range of product design applications
- Power and flexibility that support virtually any design methodology, whether top-down or bottom-up
- Foundation for product lifecycle management
- Extendable with a selection of add-on application modules

All of the NX X solutions share a common denominator of high-performance CAD functions and powerful high-definition 3D (HD3D) Visual Reporting, enabling designers and engineers to quickly understand key elements of their designs. Each level of the solutions builds upon the other, providing increasingly sophisticated and advanced design capabilities.

NX X Design Standard

The NX X Design Standard entry-level software solution includes:

- Tools for creating and editing designs of typical mechanical components and assemblies with solid modeling and drafting, basic freeform modeling and sheet metal design
- Tools for design review, rapid prototyping, web publishing, validation checking, a reuse library and custom program execution
- Design-oriented stress and vibration analysis wizards
- Tools for integrating with Teamcenter to provide powerful data management and visualization capabilities for product and process management

NX X Design Advanced

The NX X Design Advanced software solution includes all the capabilities of NX X Design Standard but also provides enhanced product design capabilities, including:

- Validation checking
- User-defined features
- Rendering
- 3D annotation for product and manufacturing information (PMI)
- Basic routing

NX X Design Premium

The NX X Design Premium software solution includes all the capabilities of NX X Design Standard and Advanced but also includes a high-performance solution with NX capabilities for advanced assembly design, advanced freeform modeling and surface analysis, design optimization and molded part validation. It also includes additional artificial intelligence (AI)-enabled features.

Enhancing basic design through production

Leveraging NX X Design solutions enables you to deliver comprehensive and scalable digital product development that addresses all stages of the product development process, from basic design through production.

Using the NX X Design packages transforms the product development process and supports dynamic change within organizations by:

- Increasing innovation throughout the product development process
- Eliminating waste by better utilizing time, material and intellectual resources
- Improving quality from the beginning



	NX X Design Standard	NX X Design Advanced	NX X Design Premium
Data Management			
Teamcenter integration for NX X	•	•	•
Base level data management	•	•	•
Design modeling			
Feature-based solid modeling	•	•	•
Synchronous technology	•	•	•
Core Convergent Modeling	•	•	•
Drafting	•	•	•
Assemblies	•	•	•
Advanced assembly modeling			•
Basic freeform modeling	•	•	•
Advanced freeform modeling			•
User-defined features		•	•
AI Select Similar Components			•
AI Selection Prediction			•
Process-specific modeling tools			
Sheet metal design	•	•	•
PMI		•	•
Basic routing		•	•
Industrial design			
Photorealistic rendering		•	•
Visualize shape		•	•
Freeform shape			•
Advanced surface analysis			•
Product validation			
Product validation		•	•
HD3D Visual Reporting OOTB reports	•	•	•
HD3D Visual Reporting custom report editing			•
Molded part validation			•
Run time licenses			
Run time for custom program execution	•	•	•
Data exchange			
DXF/DWG, IGES, STEP 203/214, JT, Solid Edge™ software open, SolidWorks open	•	•	•

With NX X Design solutions, you can gain key advantages such as:

- A unified solution – seamless application integration rapidly propagates changes to product and associated process information
- Teamcenter integration – all tools necessary to integrate with Teamcenter
- Knowledge-driven automation – reuse product and process knowledge across all elements and phases of product development
- Integrated simulation and validation – comprehensive simulation and validation tools check product performance and manufacturability throughout every step of product development

NX X Design capabilities

Teamcenter Integration for NX X

NX X offers full integration with Teamcenter software. The powerful data management system includes tools for vaulting, check-in/check-out, revision management, attribute synchronization and searching. It also includes data conversion capabilities for generating visualization files.

Design modeling

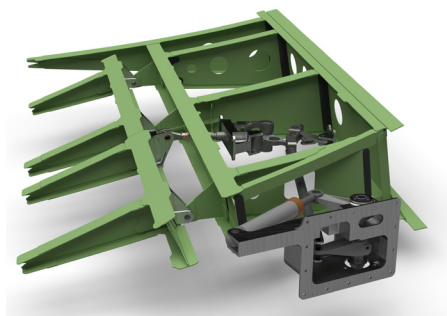

Feature-based solid modeling

The core modeling capability in NX combines wireframe, surface, solid, parametric and direct modeling in a single environment that enables designers to choose the most appropriate tool for the task at hand. Using NX delivers full feature-based parametric solid modeling and advanced features, including blends, thin-wall, draft, mirrored features, open profile features and patterns. Additionally, it can support creating 2D/3D wireframe models, swept and revolved solids, Boolean operations and basic parametric editing. This includes variational sketching tools for quick and efficient conceptual design as well as tools for general modeling and editing tasks. Models retain their original parametric values, and you can edit them using intuitive dimension-driven techniques.

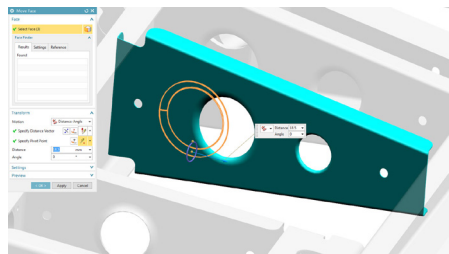

Synchronous technology

Direct modeling with synchronous technology offers a fast and intuitive approach for creating and editing designs using simple push-and-pull methods, and enables you to work directly with geometry created with other CAD systems. For greater versatility and design flexibility, you can use synchronous modeling interchangeably with other modeling tools. A configurable, role-based user interface (UI) displays the commands you need as you need them and grows as your experience level grows.

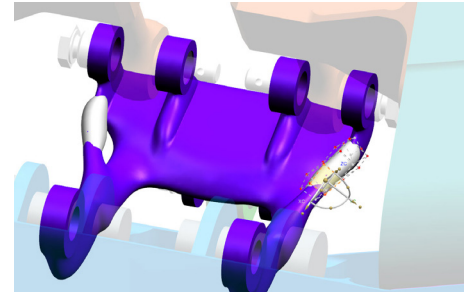

Core Convergent Modeling

Convergent Modeling™ technology is a game-changing technology for working with facet geometry. It is now possible to design with facet geometry using the same parametric, feature-based methods that are used with traditional CAD geometry. You can use familiar feature-based modeling tools (Boolean, trim, offset, shell, scale, taper, blend, chamfer) when working with facet geometry. Designers can work with facet geometry in assembly modeling, drafting, PMI and other applications.

Drafting

Using NX Drafting automates and streamlines engineering drawing production. Drawings are associative to models, so model changes automatically update and are reflected in related drawings. Drafting capabilities include dimensioning, symbols, tabular notes, sheet layout and placement of standard orthographic and auxiliary views, automatic view creation from the 3D model, hidden line processing and automatic parts list generation.

Additionally, you can drag and drop templates that include drawing borders and view layouts into models to automate much of the work associated with manually created drawings. You can also configure drafting tools to comply with the drawing standard selected by the user (ANSI, ISO, JIS, DIN, GB and ESKD).

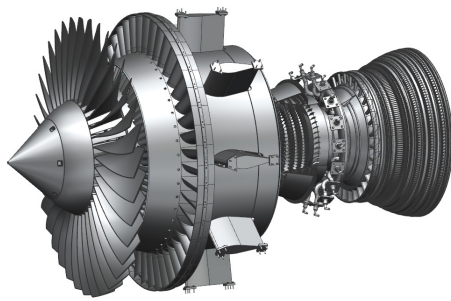

Assemblies

Leveraging NX Assemblies supports top-down and bottom-up assembly modeling. It supports the design-in-context approach, where changes can be made to any component of the design model while working in the context of the assembly. Easily traverse assemblies using the assembly navigator in conjunction with intelligent component searching capabilities. NX Assemblies also includes support for creating flexible assemblies and parts, enabling various component arrangements and configurations, such as springs and pistons.



Advanced assembly modeling

With the advanced assembly modeling capabilities in NX X Design Premium, you can simplify components or subassemblies into a single lightweight solid, enclose assembly geometry in an envelope of planar faces, partition assemblies into meaningful regions and manage the weight and other mass properties of components and assemblies.

Basic freeform modeling

Basic freeform modeling is a core suite of tools for creating freeform solid or surface shapes from wireframe geometry. This includes history-based parametric methods. Creation methods include offsets, extensions, rulings, lofts, sweeps, networks and boundary fill. It also provides support for tangent and curvature-continuous shapes.

Advanced freeform modeling

Advanced freeform modeling extends the NX basic freeform capability to include shapes driven by laws and conics, blended shapes controlled by guiding curves, flange surfaces, guided construction of surfaces from facet meshes, midsurface construction and the ability to globally deform solid or surface shapes.

User-defined features

You can use NX to capture and store families of features for easy retrieval, editing and reuse. User-defined features enable designers to establish relationships between parameters, define feature variables, set default values and decide the general form the feature will take. User-defined features reside in a reuse library that is accessible to anyone using NX modeling.

AI Select Similar Components

NX X Design Premium includes additional functionality driven by AI that declutters assemblies and boosts productivity by reducing the number of clicks for performing operations. Machine learning-enabled shape recognition selects geometrically similar components that can then have the same operation performed on all selected components simultaneously.

AI Selection Prediction

In addition to AI Select Similar Components, NX X Design Premium includes another AI-driven tool that enables productivity gains for multiple select workflows. The AI Selection Prediction framework predicts input selection entities. Designers can preview predicted objects with a user-defined attention color, select the predicted objects and add or remove predicted entities from the selection list.

Process-specific modeling tools

Sheet metal design

NX includes solid modeling tools that focus on design for manufacturing sheet metal parts. Designers can create sheet metal component models using feature-based design tools for tabs, flanges and other features. You can define forming tables and bend sequence tables, and flatten and reform the solid model, considering material deformation properties. The sheet metal tools generate accurate flat pattern data for downstream applications.

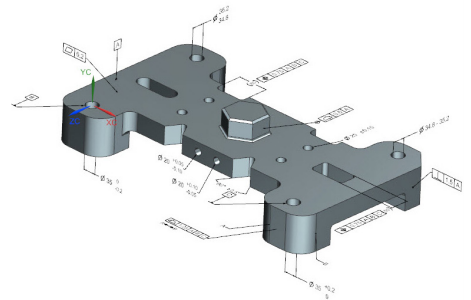

PMI

Using NX PMI enables designers to digitally author 3D annotation and product data as a solid part or assembly. PMI includes 3D dimensions, geometric dimensioning and tolerancing (GD&T) data, such as datums and feature control frames, 3D notes and customizable nongeometric information, which you can directly associate with an NX model.

Basic routing

NX X Design Advanced and Premium deliver routing capabilities for designing pipe, tube and cable runs. The routing tools also enable intelligent part selection and placement of standard components such as elbows and tees. You can extend the routing capabilities by adding discipline-specific functionality for advanced applications, including cabling, piping and tubing and heating, ventilation and air conditioning (HVAC) design.



Industrial design

Rendering

NX includes a high-end, realistic and photorealistic display for communicating product designs. Using Advanced Studio to dynamically visualize and inspect realistic displays of the designs throughout the design and manufacturing process helps you understand them better, make better decisions faster and shorten the design cycle for more innovation. You can use Ray Traced Studio photorealistic rendering to produce images for design reviews, marketing or sales collateral and catalogs or manuals earlier in the process, speeding up time-to-market. Additionally, this includes libraries of physical-based materials and scenes with image-based lighting schemes for easy setup. Editing tools enable designers to change them or create new ones.

The studio task environment streamlines rendering workflows with a concise set of tools and context-specific commands that streamline setting up rendered images.

Freeform shape

A comprehensive suite of tools for industrial design, styling and reverse engineering. With these tools, designers can create high-quality (Class-A) freeform shapes and develop styled primary, secondary and tertiary surfaces (styled sweeps, blends and corners). The tools fully support Class-A working methods (surface shaping, fitting, snipping and edge matching) to achieve up to G3 curvature continuity. With the reverse engineering capabilities, designers can import facet scans into fully parametric traditional CAD models, detect shape from the facets (primitive and curvature-based) and fit curves and surfaces (planes, cylinders, cones, spheres and freeform) as parametrically editable features. The power of features and synchronous modeling streamlines the detailing and editing of designs.

Advanced surface analysis

A comprehensive suite of tools for checking CAD models meet geometric, manufacturing and aesthetic quality standards. The tools check for deviation, continuity, draft, radius, curvature, highlights, reflections, gaps and flushness.

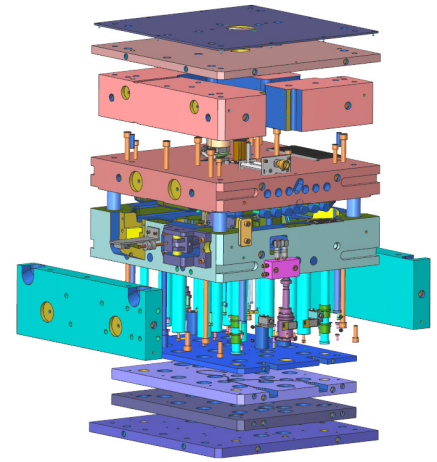

Product validation

Check-Mate validation runtime

Using the Check-Mate tool, you can set up and enforce rules to monitor design integrity and improve product quality. This product validation tool includes various standard checks for files, models, drawings and assemblies. Additionally, you can use HD3D Visual Reporting to deliver the validation check results.

Molded part validation

NX X Design Premium includes a molded part validation tool that enables designers to check moldability, even if they know little about mold design. NX analyzes parts and automatically provides designers with information about draft angles, undercut areas, sharp corners, small radiuses and other items that could compromise molding quality. It also provides designers with an easy visual check of the core and cavity sides.

HD3D Visual Reporting

Using HD3D Visual Reporting software blends information of interest from your company's data sources directly into the 3D product design environment. This helps designers make unambiguous assessments, interpret information more accurately and synthesize product and process data rapidly to make correct design decisions.

HD3D Visual Reporting comes with a set of predefined, out-of-the-box (OOTB) reports that provide design teams with answers to commonly asked questions. Reports related to ownership, check-out, part maturity, projects, load status, validation status and more are available for instant use. With the authoring capability, companies can create and modify custom reports to extract and present the data.

Runtime licenses

NX X Design solutions can run your created applications with our wide range of application programming interfaces (APIs).

Translators/interfaces

Data exchange

NX data exchange tools include the most commonly used translators needed to bring data into and out of NX, such as IGES, STEP AP203, STEP AP214, DXF/DWG, STL and 3MF. These translators include geometry repair and simplification capabilities to ensure the most useful data possible. You can run all of the translators externally from NX or directly inside NX using the File Import/Export and File Open/Save As commands or from the command line, making them customizable to any workflow.

**Siemens Digital
Industries Software**
siemens.com/software

Americas
1 800 498 5351

Europe
00 800 70002222

Asia-Pacific
001 800 03061910

For additional numbers, click [here](#)

© 2024 Siemens. A list of relevant Siemens trademarks can be found [here](#). Other trademarks belong to their respective owners.

85109-D15 6/24 K