



SIEMENS DIGITAL INDUSTRIES SOFTWARE

Simcenter 3D for electromagnetics simulation

Integrating Simcenter MAGNET and high-frequency electromagnetic solvers to achieve excellent performance

Solution benefits

Enable low- and high-frequency electromagnetics simulation in a multi-discipline integrated environment

Manage and simulate highly complex multiscale models in a reasonable amount of time

Use advanced algorithms to enhance readily available material data for high-fidelity simulations

Use integrated EM-thermal solvers to predict permanent magnets' demagnetization and hot spots for increased robustness

High fidelity analysis to allow analyzing the most complex EMC phenomena inside the electric cables

Simcenter™ 3D software for electromagnetics (EM) offers an integrated, low-frequency solver with Simcenter™ MAGNET™ software and a variety of high-frequency solvers for wave propagation phenomena. Its comprehensive set of capabilities provides insight into diverse design challenges: performance of electromechanical components and energy conversion, antenna design and siting (small to large scale), electromagnetic compatibility (EMC) and electromagnetic interference (EMI).

Analyze large-scale, system-level problems efficiently

Simcenter 3D for electromagnetics integrates capabilities that can generate, manage and simulate highly complex multiscale models in a reasonable amount of time and with minimal computational resources. There are efficient and effective methods tuned for each frequency/time range, application field and scale of device. Simcenter is a part of Xcelerator, a comprehensive and integrated portfolio of software and services from Siemens Digital Industries Software.

SIEMENS

[siemens.com/simcenter3d](https://www.siemens.com/simcenter3d)

Simcenter 3D for electromagnetics simulation

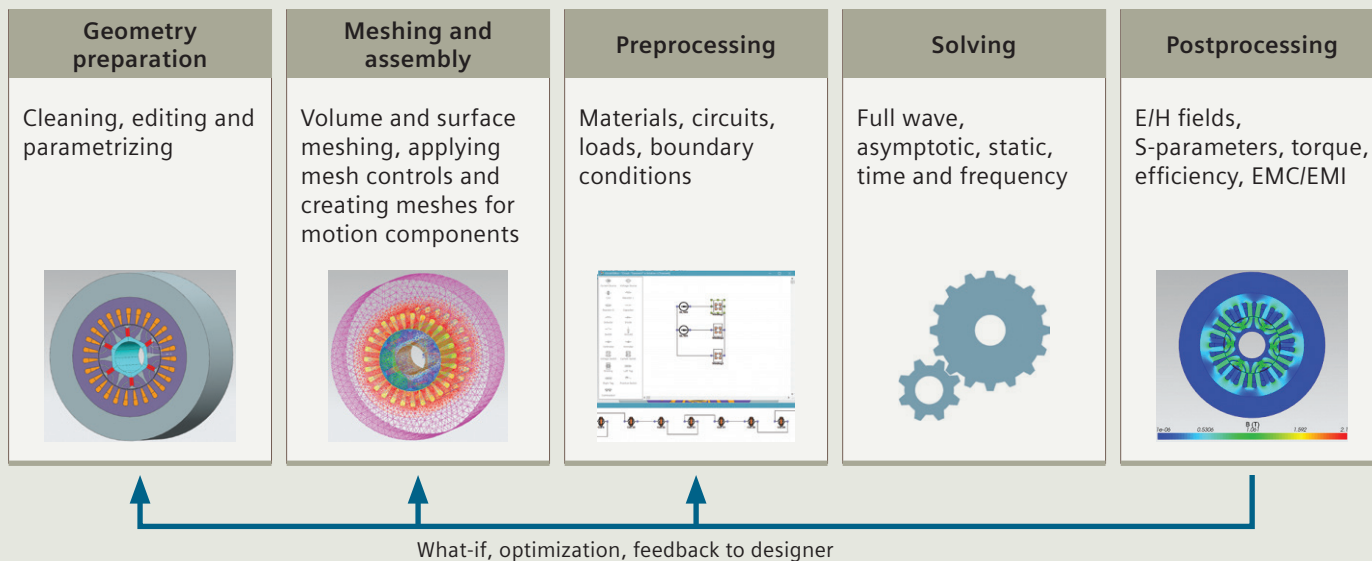

Dedicated and robust electromagnetic solvers

Simcenter 3D for electromagnetics is designed for robustness and computational efficiency. A range of dedicated solvers (time and frequency based; linear and nonlinear, finite and boundary element based) with novel boundary conditions and smart mesh refinements offers a transformative computer-aided engineering (CAE) process, with simulations ranging from a fast, initial analysis to inherent realism for final verification.

Further refinement with integrated thermal simulations

Reliable and accurate results can only be obtained when models incorporate the right level of sophistication. Coupling high fidelity electromagnetic and thermal solvers facilitates realistic predictions of the temperature distribution and the corresponding effect on materials and low-frequency electromagnetic fields. This integrated thermal simulation provides further insights, ultimately resulting in reduced risk for demagnetization and performance drop.

Deliver high-fidelity simulations with advanced material models

The Simcenter 3D electromagnetics solution uses advanced algorithms to enhance readily available material data so simulation results strongly correlate with test data and expected performance. These capabilities include modeling

manufacturing processes, temperature dependencies and magnetization imprints. Smart or engineered materials, which have uncommon electromagnetic properties, are modeled with high fidelity.

Providing a platform for multidisciplinary simulation

The Simcenter 3D EM solution is part of a larger, integrated multidisciplinary simulation environment with centralized pre- and postprocessing for all Simcenter 3D solutions. This integrated environment helps you achieve faster CAE processes and streamline multidisciplinary simulations that integrate electromagnetics and other disciplines like noise, vibration, and harshness (NVH) and computational fluid dynamics (CFD) to generate a high fidelity comprehensive digital twin and examine all core physics for product compliance, safety and performance verification.

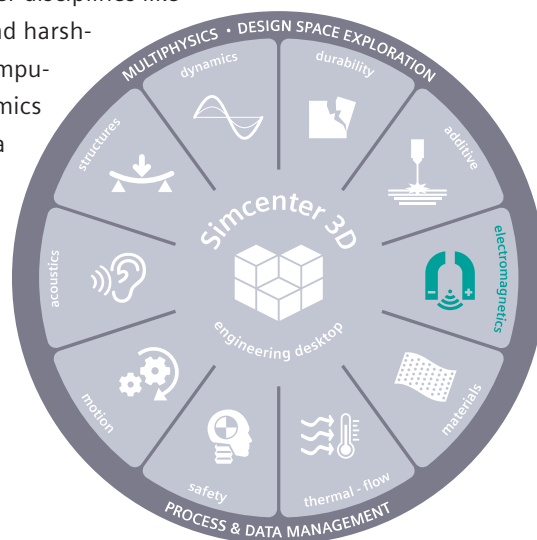

Industry applications

Electromagnetics heavily impacts product safety, performance and reliability, so having a comprehensive digital twin that can faithfully predict the multiple characteristics of this phenomenon is critical for design success.

Automotive and transportation

Simcenter 3D for EM provides the tools for designing electric vehicles (EVs) and hybrid electric vehicle (HEV) powertrains and electromechanical components (pumps, actuators), and verifying electromagnetic emissions (both radiated and conducted) to meet regulations and develop antennas and communication devices for vehicle to vehicle or infrastructure (V2x) connectivity.

Aerospace and defense

Simcenter 3D can tackle the complex large-scale simulations of high-intensity radiated fields and lightning on the fuselage. Also, EMC requirements for avionics can be addressed for the most complex systems. New electric propulsion can be designed with high-end electromagnetic motion solvers.

Marine

Simcenter 3D can provide insight into antenna placement and minimization of radar signature. The performance of propulsion motors, energy storage systems and rails can also be predicted.

Industrial machinery

Simcenter 3D provides the necessary features to evaluate the performance and durability of the electromechanical components used in heavy vehicles, inspection and extraction equipment.

Consumer goods

Simcenter 3D can be used to verify EMC/EMI requirements and guarantee proper function of the electronics in all environments. Further, it is used to evaluate the performance of communication systems based on antenna types and provide insight into electromechanical components (motors, pumps, fans) used in home appliances, including wireless charging.

Static, harmonic and transient low frequency field simulations

Coupled EM-thermal and EM-motion solvers

MoM and MLFMA

UTD and IPO

Synthetic antenna models

Surface-partial element equivalent circuit (S-PEEC)

Simulate multiscale models

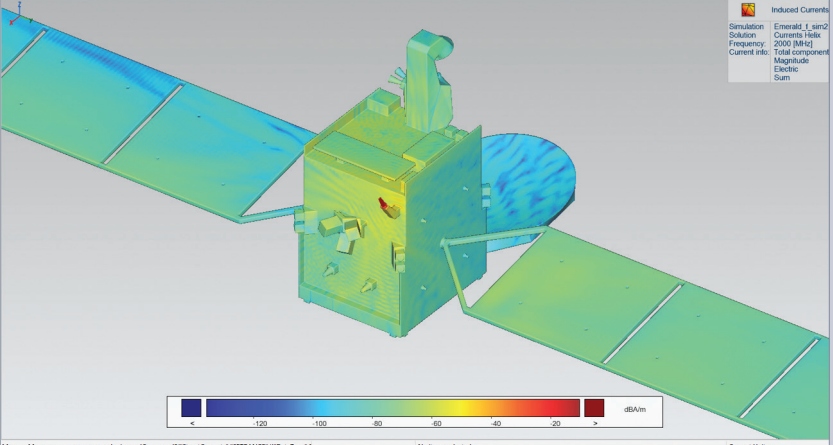

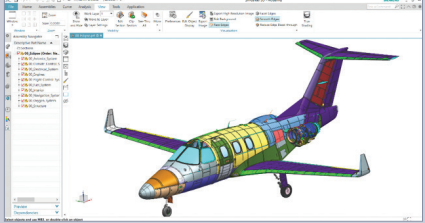
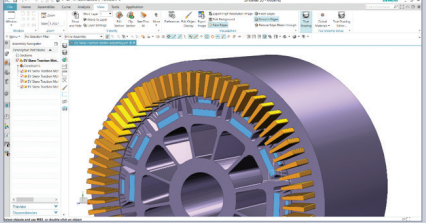
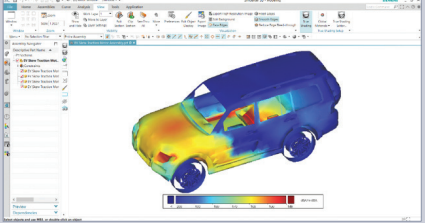
Simcenter 3D

Low Frequency EM

Simcenter 3D Low Frequency EM software allows you to create and edit Simcenter MAGNET models. Using the Simcenter 3D graphical interface, you can import or build 3D electromechanical models in native NX® CAD software, use and define sophisticated magnetic materials and define properties, boundary conditions and loads, including loads using an integrated 1D circuit modeling tool.

Once solved, the product also allows you to do sophisticated postprocessing of the results.

Module benefits

- Associativity between electromagnetic performance and the fully parametrized CAD model
- Highly efficient way of defining complex electromechanical devices
- Integrated world-class material database
- Supports multidiscipline scenarios from the integrated environment

Key features

- From 2D to full 3D detailed analysis
- Includes static, time-harmonic and transient solvers, including motion for any number of components
- Material models for low frequency electromagnetics materials (advanced models such as hysteresis, demagnetization)
- Integrated thermal analysis

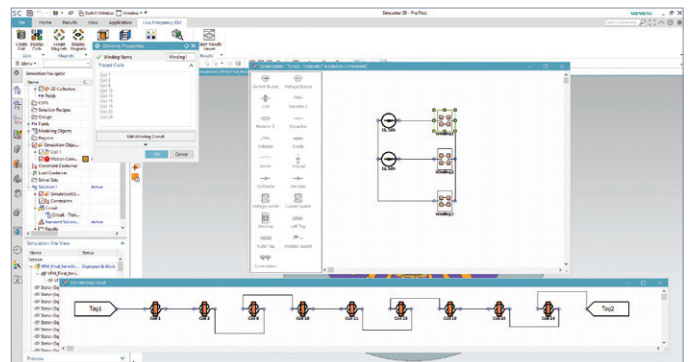
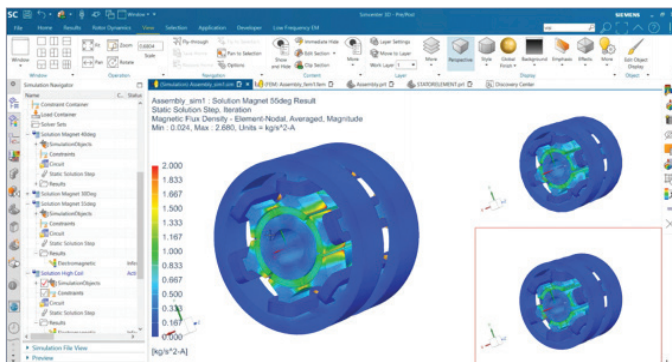

Simcenter MAGNET

Electromagnetic solver

The Simcenter MAGNET solver is based on low frequency electromagnetic solving technology, which is built on several decades of expertise and incorporates a wide range of capabilities and technologies for maximum performance for each application. The solver includes static, time-harmonic, and transient solver capabilities with motion. It is designed for motor engineers and electromagnetic engineers who want to improve design and achieve maximal performance and efficiency in their electromechanical systems.

Module benefits

- Achieve great accuracy due to outstanding capabilities
- Fast solvers, adapted and optimized for applications
- Benefit from an extensive electromagnetic materials library

Key features

- From 2D axisymmetric and 2D translational to full 3D models
- From static to time-harmonic, and full transient
- From single component to any number of components with motion
- Sophisticated loss models including hysteresis
- Circuit editor for fully coupled electromagnetic-circuit simulations

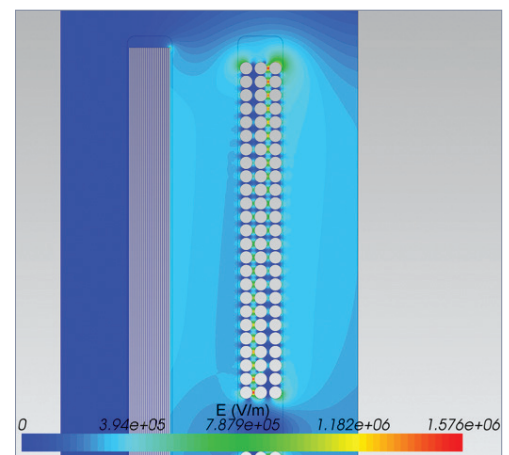
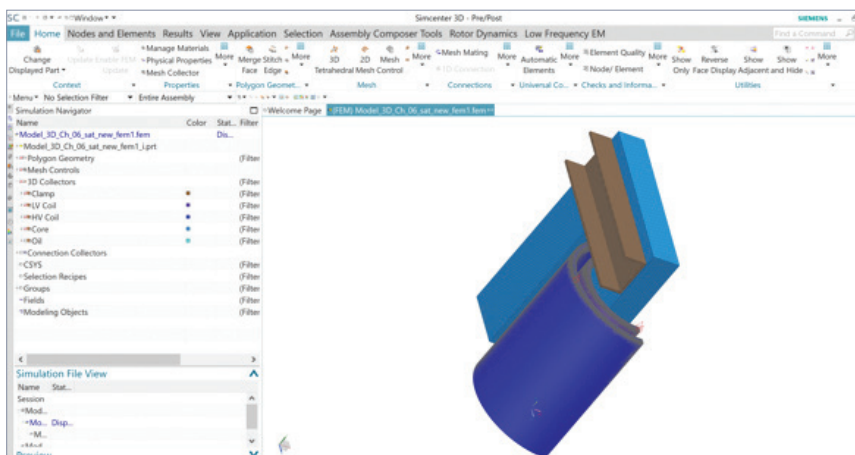

Simcenter MAGNET

Thermal solver

The thermal and electromagnetic modules of Simcenter MAGNET can be used to simulate steady-state and transient temperature distribution, considering losses in the windings as well as the core, including the eddy current and hysteresis losses

Module benefits

- Increase efficiency of electromechanical devices by considering the thermal effects
- Assess risk of demagnetization of permanent magnets and increase robustness
- Run your models in different operating conditions and easily assess effect of thermal behavior on device performance (torque, efficiency, demagnetization)

Key features

- Coupled thermal-electromagnetics co-simulation
- Steady state
- Transient

Simcenter 3D High Frequency EM

Simcenter 3D High Frequency EM software allows you to create, edit and postprocess high-frequency electromagnetic analyses from the Simcenter 3D graphical interface. The user can define complex materials, element properties, boundary conditions and excitations, including highly performant equivalent antenna models, all while keeping associativity to CAD.

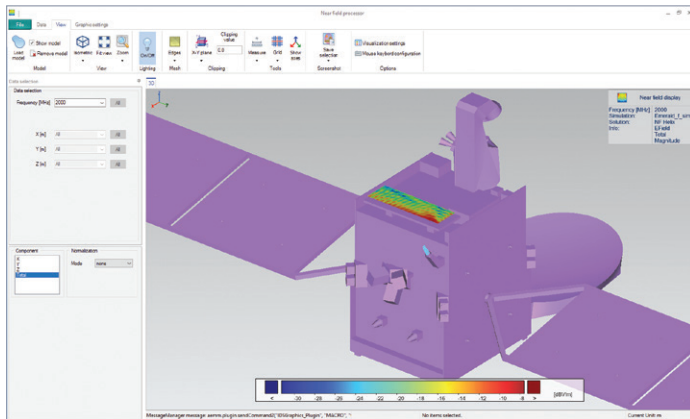
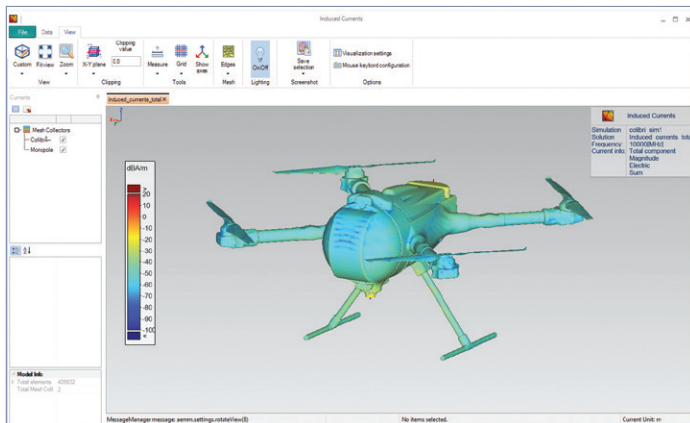

Module benefits

- Enable end-to-end efficient process using associativity between the electromagnetic performance and the CAD model
- Facilitate straightforward handling of large, system-level models such as full aircraft, satellites, ships and cars
- Address a wide frequency spectrum with a range of dedicated solvers
- Leverage existing knowledge built on 30 years of expertise in the high-frequency electromagnetics domain

Key features

- Simcenter 3D environment for high-frequency EM
- Setting up for a range of dedicated solvers: uniform theory of diffraction (UTD), 3D and 2.5D (for devices and antennas based on multilayered PCB technology), accelerated multilevel fast multipole algorithm (MLFMA, DDM...) and MoM-based solvers
- Material models for high-frequency electromagnetics
- Postprocessing of analysis: EM fields, SYZ parameters, coupling, far-field and near-field results, magnetic and electric currents, antenna pattern
- CAD-based and equivalent models of antenna (antenna modeling starting from incomplete data)

Simcenter High Frequency EM solver

The Simcenter High Frequency EM solver embeds full-wave solvers based on integral methods (MoM and MLFMA) for solving Maxwell's electromagnetic equations. In addition, asymptotic methods are available based on the UTD and IPO. A variety of solvers are incorporated to efficiently solve for 2.5D as well as for full 3D field problems. Solver acceleration options (multiboundary conditions MoM-based algorithms, accelerated through MLFMA, DDM and other fast algorithms) are embedded to speed up computation times for large systems.

Module benefits

- Availability of a wide range of solvers allows you to select the most appropriate one for the job
- Ultra-large-scale problems (large electric size) can be handled
- Run models with different length scales (small antennas integrated in large systems can be handled efficiently)
- Solver accelerators provide extra speed

Key features

- Full wave: MoM, MLFMA and S-PEEC
- Asymptotic: UTD and IPO
- Variety of sources: plane wave, dipole, port excitation, directivity pattern
- Synthetic (equivalent) antenna models
- Multilayer substrates

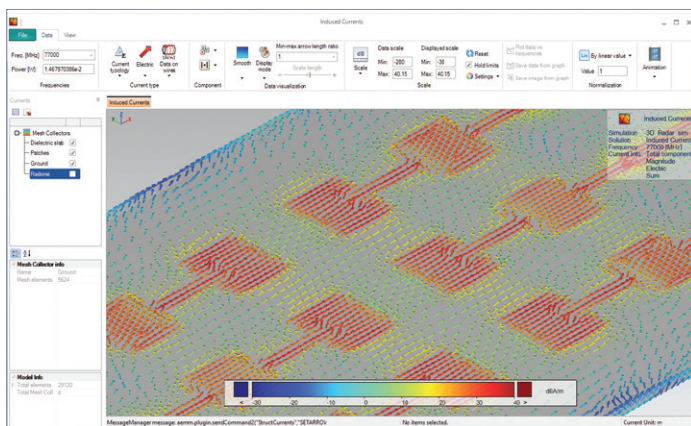
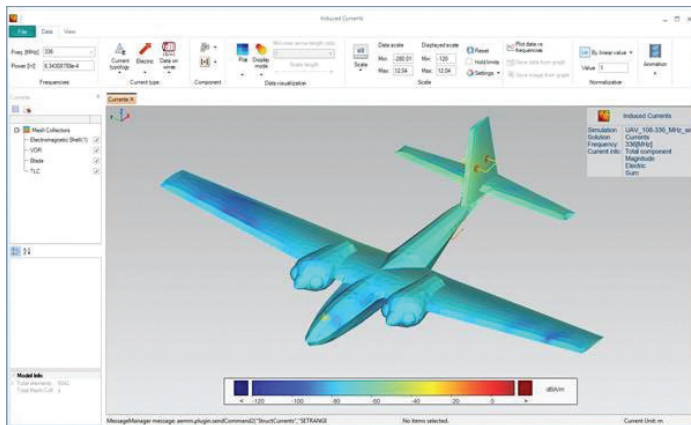

Simcenter 3D

Wire harness electromagnetic capability

The Simcenter™ 3D software wire harness electromagnetic capability (EMC) option on Simcenter 3D high frequency electromagnetic (EM) allows you to analyze the EMC performances of electric wire harnesses. These can be composed of any number of branches, with a general cross section information of the bundle: cables with any number of conductors and general cross section geometries. Wire harnesses are directly imported from CAPITAL™ software, the world leading wire harness engineering tool, into Simcenter 3D including automatic generation of the 3D path from CAPITAL and assignment of properties, making the EMC analysis highly efficient.

The integrated multiconductor transmission line network (MTLN) solver combined with the Simcenter 3D high frequency EM solver allows you to perform any EMC-related analysis on the wire harness, such as emission, susceptibility, and cross talk within the bundle and between bundles.

Module benefits

- Highly efficient process with import from CAPITAL with automatic generation of the electric wire model in Simcenter 3D
- High fidelity analysis to allow analyzing the most complex EMC phenomena inside the electric cables
- Intuitive editor to specify bundle properties
- Wide range of post-processing capabilities

Key features

- Multiconductor Transmission Line Network (MTLN).
- Direct Import from CAPITAL with automatic creation of the wire harness model in Simcenter 3D
- Electric cable cross section editor
- MTLN coupling with 3D full wave EM solvers (3D MoM, 2.5D MoM, S-PEEC)
- Emission, Susceptibility and Cross talk



Instrument panel of a vehicle.

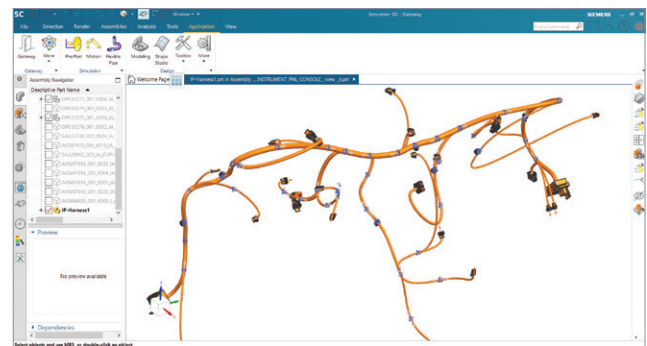

Wire harness of the instrument panel.

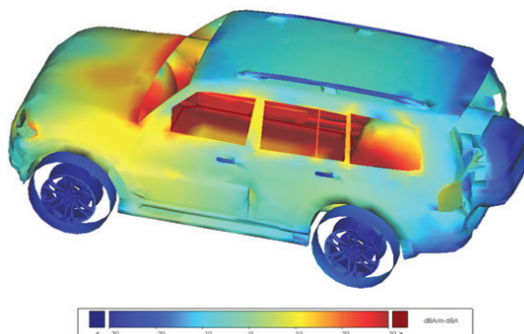

Current distribution in a car caused by high voltage electric cables.

Capabilities chart

General capabilities	Specific capabilities	Simcenter 3D Low Frequency EM	Simcenter MAGNET solver	Simcenter MAGNET Thermal solver
		Low-frequency electromagnetics		
Meshing	Automatic airgap remeshing with motion		•	
	Adaption		•	•
Boundary condition	Periodic	•		
	Flux tangential	•		
	Field normal	•		
	Thin plate	•		
	Perfect electric insulator	•		
	Surface impedance (linear and nonlinear model)	•		
	Perfect Thermal Insulator	•		
	Ground	•		
	Thin resistive sheets	•		
	Specified temperature	•		
Materials	Material library for low-frequency EM (extensive set of materials)	•		
	Models for low-frequency EM materials (advanced models: hysteresis, demagnetization)	•		
	Magnet orientation	•		
Loads and excitations	Coils definition (body, face)	•		
	Coil excitation (current and voltage driven)	•		
	Circuit (strongly coupled)	•		
	Motion components (velocity and load driven, multiple degrees-of-freedom)	•		
	Electrodes	•		
Electromagnetic solver	2D axisymmetric		•	
	2D translational		•	
	3D		•	
	Static		•	
	Transient		•	
	Time Harmonic		•	
	Transient with motion		•	
Coupled thermal - electromagnetic (steady state or transient thermal)				•

General capabilities	Specific capabilities	Simcenter 3D Low Frequency EM	Simcenter MAGNET solver	Simcenter MAGNET Thermal solver
		High-frequency electromagnetics		
Electric Field solver	2D axisymmetric		•	
	2D translational		•	
	3D		•	
	Static		•	
	Transient		•	
	Time Harmonic		•	
	Current Flow		•	
Coupled thermal - electric field (steady state or transient thermal)				•
Post-processing	Field results (B-field, E-field, temperature, etc.)	•		
	Quantities (voltage, current, energy, loss, force, torque, flux-linkage, temperature, heat flow, etc.)	•		
	Motion (magnetic force/torque, load force/torque, position, speed, acceleration, etc.)	•		
	Field results (E-field, Voltage, Charge density, Conductivity, Displacement currents, Permittivity, Surface charge density, temperature, etc.)	•		
Quantities (Charge, Forces and torques, Voltage, Stored electric energy)	•			
General capabilities	Specific capabilities	Simcenter 3D High Frequency EM	Simcenter High Frequency EM solver	Wire harness electromagnetic
		High-frequency electromagnetics		
Boundary condition	Electric field integral equation (EFIE)	•		
	Magnetic field integral equation (MFIE)	•		
	Combined field integral equation (CFIE)	•		
	Poggio-Miller-Chang-Harrington-Wu-Tsai (PMCHWT)	•		
	Impedance boundary conditions (IBC) of first and high order	•		
	Network IBC (NIBC) of first and high order	•		
	Thin sheet of first and high order	•		
	Mixed-potential integral equation (MPIE)	•		

General capabilities	Specific capabilities	Simcenter 3D High Frequency EM	Simcenter High Frequency EM solver	Wire harness electromagnetic
High-frequency electromagnetics (continued)				
Excitation	Port excitation (delta-gap)	•		
	Magnetic and electric dipoles	•		
	Plane wave	•		
	Synthetic antenna models	•		
	SWE (spherical wave expansion)	•		
	3D pattern	•		
Materials	Models for high-frequency EM materials	•		
	PEC, lossy metallic surface, dispersive materials, RAM, bulk dielectrics structure, composite laminate stack up, characterized by measurements	•		
Solution	2.5D frequency domain MoM		•	
	3D frequency domain MoM		•	
	Surface-partial element equivalent circuit (S-PEEC)		•	
	Asymptotic ray based UTD		•	
	Asymptotic current-based (iterative physical optics)		•	
	Inter-antenna coupling		•	
	Fast antenna modeling tools		•	
	Reverse sourcing tools		•	
Acceleration methods	Sparse matrix-adaptive integral method (SM-AIM)		•	
	Multi-resolution - multilevel fast multiple algorithm (MLFMA)		•	
	Fast near-/far-field computation		•	
	Adaptive cross approximation (ACA)		•	
	Fast far-field approximation (FaFFA)		•	
	Hardware: multi graphics processing unit (GPU)		•	

General capabilities	Specific capabilities	Simcenter 3D High Frequency EM	Simcenter High Frequency EM solver	Wire harness electromagnetic
Wire harness application	Import from Capital			•
	Baum, Liu and Tesche (BLT) formulation			•
	Multiconductor Transmission Line Network (MTLN)			•
	Emission			•
	Susceptibility			•
	Cross talk (intra and inter bundle)			•
	Cable List editor			•
	Harness topology editor			•

Note: Simcenter 3D Engineering Desktop is a minimum prerequisite for all Simcenter 3D products. Other dependency or prerequisites may apply for individual products.



Siemens Digital Industries Software

[siemens.com/software](https://www.siemens.com/software)

Americas 1 800 498 5351

Europe 00 800 70002222

Asia-Pacific 001 800 03061910

For additional numbers, click [here](#).

© 2021 Siemens. A list of relevant Siemens trademarks can be found [here](#). Other trademarks belong to their respective owners.